



US005852331A

United States Patent [19]
Giorgini

[11] **Patent Number:** **5,852,331**
[45] **Date of Patent:** **Dec. 22, 1998**

[54] **WIND TURBINE BOOSTER**
[76] Inventor: **Roberto Giorgini**, P.O. Box 2051, St. Maarten, Netherlands Antilles
[21] Appl. No.: **667,405**
[22] Filed: **Jun. 21, 1996**
[51] **Int. Cl.⁶** **F03D 3/04**
[52] **U.S. Cl.** **290/55; 290/44; 415/4.2; 415/4.4**
[58] **Field of Search** 290/43, 44, 54, 290/55; 415/4.2, 4.4, 907; 416/197 A

4,508,973	4/1985	Payne	290/55
4,551,631	11/1985	Trigilio	290/55
4,764,683	8/1988	Coombes	290/55
5,038,049	8/1991	Kato	290/55
5,391,926	2/1995	Staley et al.	290/55
5,457,346	10/1995	Blumberg et al.	290/55
5,664,418	9/1997	Walters	60/398

Primary Examiner—Clayton E. Laballe
Assistant Examiner—Nicholas Ponomarenko
Attorney, Agent, or Firm—Michael I. Kroll

[57] **ABSTRACT**

A booster (34) for a wind turbine (12) of the type containing an impeller (14) having a plurality of radial curved vanes (16) mounted on a shaft (18) connected to an electric generator (20). The booster (34) comprises a structure (36) mounted in a stationary manner about the impeller (14) for increasing rotation speed of the radial curved vanes (16) on the shaft (18) and operate more efficiently the electric generator (20), to put out more electrical energy therefrom.

[56] **References Cited**
U.S. PATENT DOCUMENTS

1,595,578	8/1926	Sovereign	
3,938,907	2/1976	Magoveny et al.	415/141
4,031,405	6/1977	Asperger	290/55
4,039,849	8/1977	Mater et al.	290/55
4,086,498	4/1978	Szoeke	290/55
4,318,019	3/1982	Teasley et al.	310/156

15 Claims, 2 Drawing Sheets

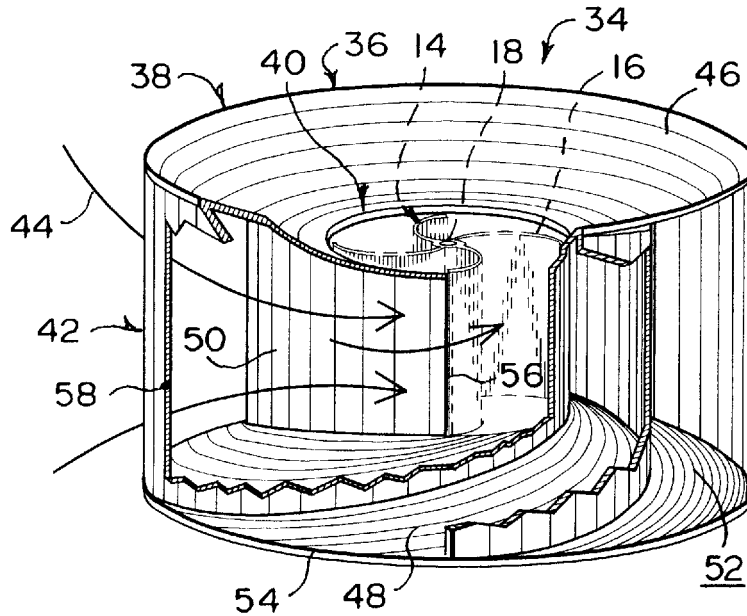

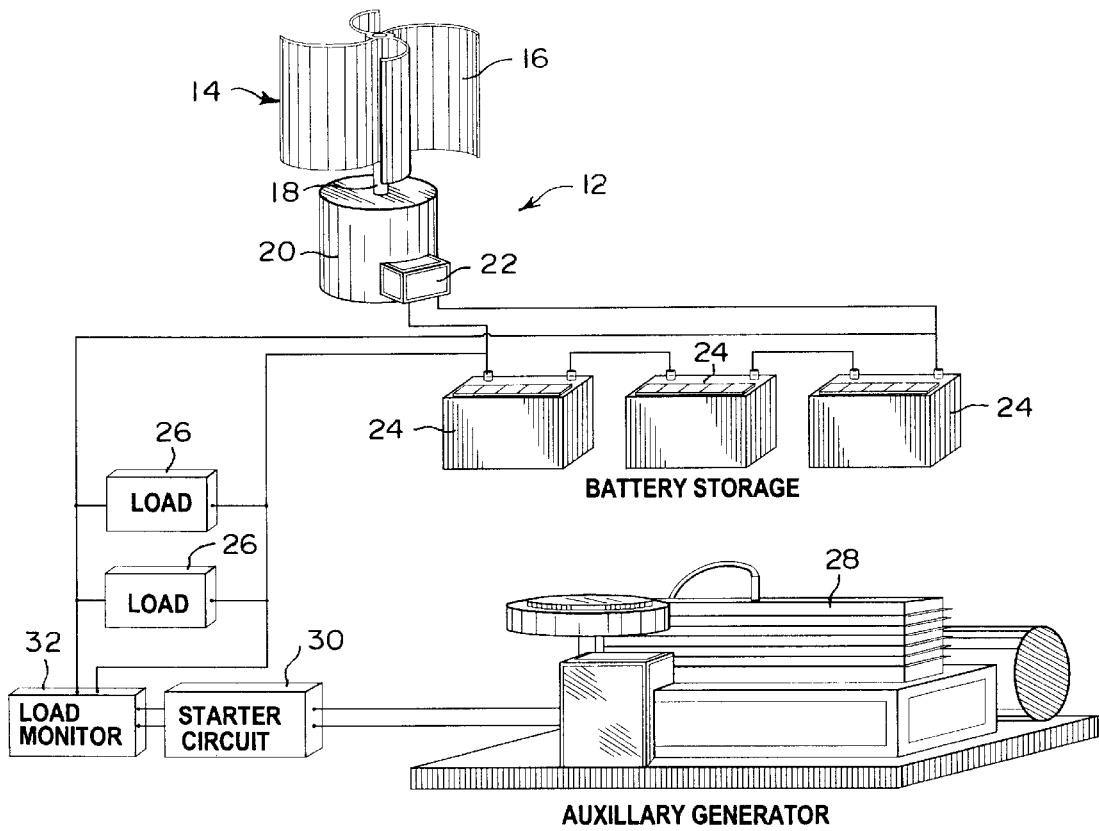
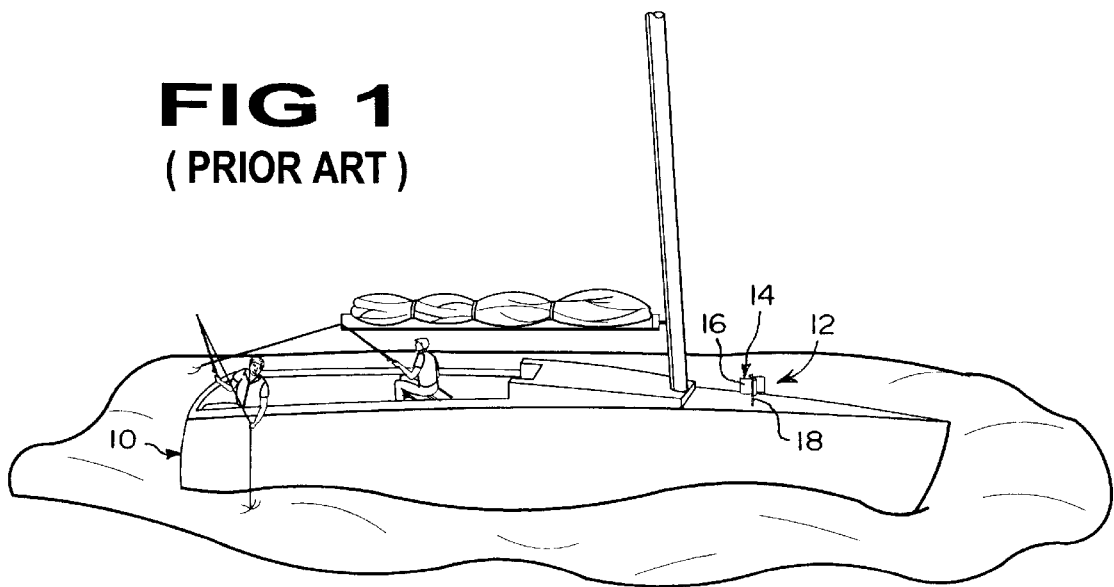

FIG 1A
(PRIOR ART)

FIG 1
(PRIOR ART)



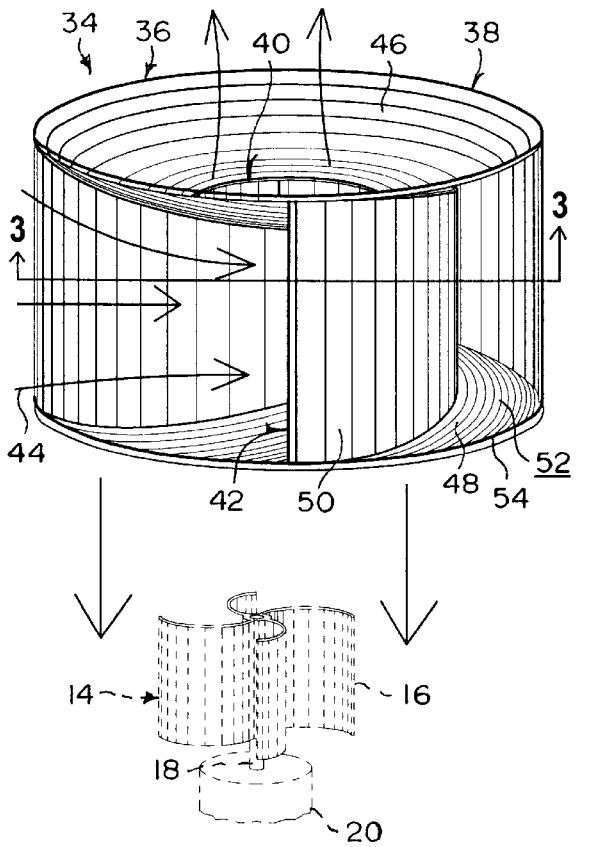

FIG 2

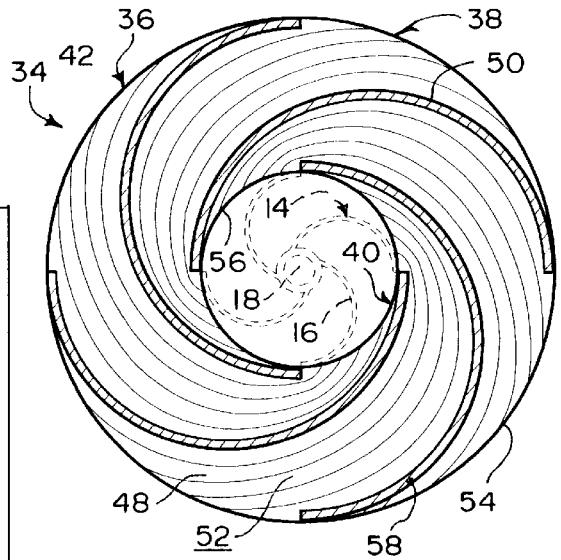

FIG 3

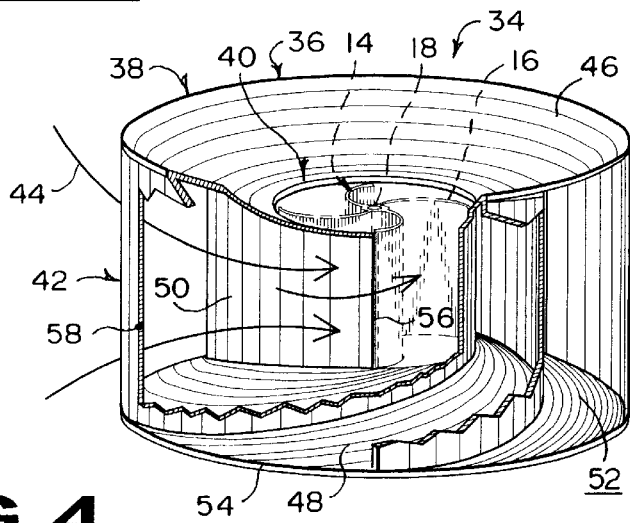

FIG 4

WIND TURBINE BOOSTER

BACKGROUND OF THE INVENTION

1. Field of the Invention The instant invention relates generally to wind operated electric generator systems and more specifically it relates to a wind turbine booster.

2. Description of the Prior Art

Numerous wind operated electric generator systems have been provided in prior art. For example U.S. Pat. Nos. 4,086,498 to Szoek; 4,508,973 to Payne; 4,764,683 to Coombes and 5,457,346 to Blumberg et al. all are illustrative of such prior art. While these units may be suitable for the particular purpose to which they address, they would not be as suitable for the purposes of the present invention as heretofore described.

A machine and method for converting the wind's linear force to electricity, comprising of a rotor, walled at both inner and periphery radiuses, encircled by a periphery deflector and its inner radius covered with a core deflector. Tapping means attached to the back planar base of its plurality of rotor vanes and rotatably associated with plurality of reciprocating generators. Rotation speed and generating electricity regulated by operating means, mounted to its axis.

A wind-operated electric generator system of simple design including a stationary circular arrangement of segmental wind inlet passages extending around a vertical axis and having vertical inlet openings at the outer ends. The inlet openings having inwardly and upwardly curving walls extending from the inlet openings toward the central axis. The lower walls sloping upwardly an appreciably greater extent than the upper walls to form an inwardly and upwardly extending convergence with the inner portions of the upper walls to form constricted upwardly directed exit passages that merge into a Venturi throat. A bladed impeller is mounted upon a vertical shaft which is connected to an electric generator. The sides of the segmental inlet passages also converging toward the central axis and cooperating with the converging upper and lower walls to form an efficient Venturi effect to increase the speed of air currents directed to the impeller.

An improved wind powered generator includes a streamlined housing rotatably connected with a fixed base and a pair of helical rotors rotatably connected with the housing for driving a pair of electric generators when the rotors are rotated by the wind. The housing includes forward and rear nacelles which define vertical side openings in the housing in which the rotors are arranged, with the helical vanes thereof partially protruding from the housing. the nacelles serve to direct the wind stream against the rotor vanes with minimal disturbance, whereby the helical rotors capture the maximum amount of kinetic energy from the wind for conversion to electricity.

An accelerator for a windmill structure as described which is a frustro-conical funnel-like device intended to direct a stream of wind therethrough onto the impeller of a windmill. As the wind passes through the device, it is constricted whereby the velocity increases and exits a throat-like outlet as a diverging jet impacting the impeller blades to thereby increase the kinetic energy available to be converted to mechanical or electrical energy by the windmill. The device of this invention can include a vane for maintaining the accelerator facing into the wind with the windmill, a mounting platform for either the accelerator or both accelerator and the windmill, and an internal configuration to the accelerator to impart a swirling spiral motion to the wind passing therethrough as it is constricted.

SUMMARY OF THE INVENTION

A primary object of the present invention to is provide a wind turbine booster that will overcome the shortcomings of the prior art devices.

Another object is to provide a wind turbine booster that is mounted in a stationary manner about an impeller of a wind turbine to increase the rotation speed of the impeller making the wind turbine more powerful.

An additional object is to provide a wind turbine booster that will direct the wind into a condensed spiraling force towards the vanes of the impeller, so that the impeller will get a much higher rotation to operate an electric generator, so as to put out more electrical energy therefrom.

A further object is to provide a wind turbine booster that is simple and easy to use.

A still further object is to provide a wind turbine booster that is economical in cost to manufacture.

Further objects of the invention will appear as the description proceeds.

To the accomplishment of the above and related objects, this invention may be embodied in the form illustrated in the accompanying drawings, attention being called to the fact, however, that the drawings are illustrative only, and that changes may be made in the specific construction illustrated and described within the scope of the appended claims.

BRIEF DESCRIPTION OF THE DRAWING
FIGURES

Various other objects, features and attendant advantages of the present invention will become more fully appreciated as the same becomes better understood when considered in conjunction with the accompanying drawings, in which like reference characters designate the same or similar parts throughout the several views, and wherein;

FIG. 1 is a perspective view of the prior art being a water craft with a wind turbine system mounted therein.

FIG. 1A is a perspective view of the prior art wind turbine system used in the water craft in FIG. 1.

FIG. 2 is a perspective view of the instant invention ready to be placed over the impeller of the wind turbine.

FIG. 3 is a cross sectional view taken along line 3-3 in FIG. 2.

FIG. 4 is a perspective view similar to FIG. 2, showing the instant invention placed over the impeller of the wind turbine, with the parts broken away and in section showing the internal structure thereof.

Similar reference characters denote corresponding features consistently throughout the attached drawings.

DETAILED DESCRIPTION OF THE
PREFERRED EMBODIMENTS

Turning now descriptively to the drawings, in which similar reference characters denote similar elements throughout the several views, FIGS. 1 and 1A illustrate the prior art. FIG. 1 shows a water craft 10 with a wind turbine 12 mounted therein. The wind turbine 12, as shown in FIG. 1A, consists of an impeller 14 having a plurality of radial curved vanes 16 mounted on a shaft 18 connected to an electric generator 20. The electric generator 20 has a connector 22 that is electrically connected to a plurality of storage batteries 24, which in turn operate loads 26 that are electrical equipment. An auxiliary generator 28 is connected to a starter circuit 30, which is connected to a load monitor

32 which will operate the loads **26** as a back up system when the wind turbine **12** is not operating.

The instant invention, as shown in FIGS. **2** to **4**, is a booster **34** for the wind turbine **12**. The booster **34** comprises a structure **36** mounted in a stationary manner about the impeller **14** for increasing rotation speed of the radial curved vanes **16** on the shaft **18** and operate more efficiently the electric generator **20**, to put out more electrical energy therefrom.

The rotation increasing structure **36** includes a generally cylindrical housing **38**, having a central core opening **40** to receive the impeller **14** therein in a rotatable manner. A facility **42** in the housing **38** is for directing wind **44** in a condensed spiraling force towards the central core **40**, so that the vanes **16** of the impeller **14** will rotate much faster.

The wind directing facility **42** consists of a top wall **46** that is downwardly tapered towards the central core opening **40** in the housing **38**. A bottom wall **48** is also provided, that is upwardly tapered towards the central core opening **40** in the housing **38**. A plurality of spiral vertical walls **50** are diverging and terminating at the central core opening **40** in the housing **38**.

The spiral vertical walls **50** split u the housing **38** into a plurality of wind passageways **52** extending spiraling around the central core opening **40** in the housing **38**. Each wind passageway **52** has a large wind inlet port **54** at external perimeter of the housing **38**. Each wind passageway **52** also has a small wind outlet port **56** at the central core opening **40** in the housing **38**.

The housing **38** and the wind directing facility **42** are fabricated out of a strong durable material **58**. The strong durable material **38**, as shown in the drawings, is metal. The strong durable material **38** can be made out of other types of matter, such as plastic, a composite, hard rubber, etc. (not shown).

OPERATION OF THE INVENTION

To use the booster **34** for the wind turbine **12**, the following steps should be taken:

1. Place the housing **38** over the impeller **14**, so that the central core opening **40** extends about the impeller **14**.
2. Secure the housing **38** in a stationary manner, so that the impeller **14** can rotate freely within the central core opening **40**.
3. The wind **44** can come from any direction and enter any one of the large wind inlet ports **54**.
4. The wind **44** will travel down the respective wind passageway **52** between two spiral vertical walls **50**, the top wall **46** and the bottom wall **48**.
5. The wind **44** will now exit at a faster rate out of the small wind outlet port **56** in the central core opening **40**.
6. The vanes **16** will now rotate faster on the shaft **18** to operate the electric generator **20** more efficiently, thereby producing more electricity for the storage batteries **24**.

LIST OF REFERENCE NUMBERS

LIST OF REFERENCE NUMBERS	
10	water craft
12	wind turbine (prior art) on 10
14	impeller of 12

-continued

LIST OF REFERENCE NUMBERS	
16	radial curved vane of 14
18	shaft of 12
20	electric generator of 12
22	connector on 20
24	storage battery
26	load (electrical equipment)
28	auxiliary generator
30	starter circuit
32	load monitor
34	booster
36	rotation increasing structure of 34
38	generally cylindrical housing of 36
40	central core opening of 38
42	wind directing facility of 36
44	wind
46	top wall downwardly tapered of 42
48	bottom wall upwardly tapered of 42
50	spiral vertical wall of 42
52	wind passageway in 38
54	large wind inlet port of 52
56	small wind outlet port of 52
58	strong durable material for 38 and 42

It will be understood that each of the elements described above, or two or more together may also find a useful application in other types of methods differing from the type described above.

While certain novel features of this invention have been shown and described are pointed out in the annexed claims, it is not intended to be limited to the details above, since it will be understood that various omissions, modifications, substitutions and changes in the forms and details of the device illustrated and in its operation can be made by those skilled in the art without departing in any way from the spirit of the present invention.

Without further analysis, the foregoing will so fully reveal the gist of the present invention that others can, by applying current knowledge, readily adapt it for various applications without omitting features that, from the standpoint of prior art, fairly constitute essential characteristics of the generic or specific aspects of this invention.

What is claimed is new and desired to be protected by Letters Patent is set forth in the appended claims:

1. A booster for a wind turbine of the type containing an impeller having a plurality of radial curved vanes mounted on a shaft connected to an electric generator, wherein wind directed at the vanes cause the vanes and shaft to rotate and thereby supply energy to power the electric generator causing the electric generator to convert the energy received from the wind turbine to electrical energy for output therefrom, said booster comprising means mounted in a stationary manner about the impeller for increasing a speed of rotation of the radial curved vanes on the shaft and thereby causing the electric generator to increase an amount of electrical energy output therefrom, said means for increasing a speed of rotation including:

- a) a generally cylindrical housing having a central core opening to receive the impeller therein in a rotatable manner; and
- b) means, in said housing, for directing wind in a condensed spiralling force towards said central core causing said the speed of rotation of the radial curved vanes of the impeller to increase, said wind directing means includes a top wall downwardly tapered towards said central core opening in said housing.

2. A booster for a wind turbine as recited in claim 1, wherein said wind directing means includes a plurality of

5

spiral vertical walls diverging and terminating at said central core opening in said housing.

3. A booster for a wind turbine as recited in claim 2, wherein said spiral vertical walls split up said housing into a plurality of wind passageways extending spiraling around said central core opening in said housing.

4. A booster for a wind turbine as recited in claim 3, wherein each said wind passageway having a large wind inlet port at external perimeter of said housing.

5. A booster for a wind turbine as recited in claim 3, wherein each said wind passageway having a small wind outlet port at said central core opening in said housing.

6. A booster for a wind turbine as recited in claim 1, wherein said housing and said wind directing means are fabricated out of a strong durable material.

7. A booster for a wind turbine as recited in claim 6, wherein said strong durable material is metal.

8. A booster for a wind turbine as recited in claim 1, wherein said wind directing means includes a bottom wall upwardly tapered towards said central core opening in said housing.

9. A booster for a wind turbine as recited in claim 1, wherein said wind directing means includes a plurality of spiral vertical walls diverging and terminating at said central core opening in said housing.

10. A booster for a wind turbine as recited in claim 9, wherein said spiral vertical walls split up said housing into a plurality of wind passageways extending spiraling around said central core opening in said housing.

11. A booster for a wind turbine as recited in claim 10, wherein each said wind passageway having a large wind inlet port at external perimeter of said housing.

6

12. A booster for a wind turbine as recited in claim 11, wherein each said wind passageway having a small wind outlet port at said central core opening in said housing.

13. A booster for a wind turbine as recited in claim 12, wherein said housing and said wind directing means are fabricated out of a strong durable material.

14. A booster for a wind turbine as recited in claim 13, wherein said strong durable material is metal.

15. A booster for a wind turbine of the type containing an impeller having a plurality of radial curved vanes mounted on a shaft connected to an electric generator, wherein wind directed at the vanes cause the vanes and shaft to rotate and thereby supply energy to power the electric generator causing the electric generator to convert the energy received from the wind turbine to electrical energy for output therefrom, said booster comprising means mounted in a stationary manner about the impeller for increasing a speed of rotation of the radial curved vanes on the shaft and thereby causing the electric generator to increase an amount of electrical energy output therefrom, said means for increasing rotation including:

- a) a generally cylindrical housing having a central core opening to receive the impeller therein in a rotatable manner; and
- b) means in said housing, for directing wind in a condensed spiralling force towards said central core causing said the speed of rotation of the radial curved vanes of the impeller to increase said wind directing means includes a bottom wall upwardly tapered towards said central core opening in said housing.

* * * * *